

# Digital Course Recorder CR-100/DCR-100

## Features

### Conventional recording paper is no longer needed

Since recorder paper and course pens are no longer used, there is no need to refill or replace consumable items making it possible to reduce running costs.

### Hand written input

Just like using a traditional paper type Course Recorder, it is possible to write information via the use of a touch pen. Additionally, port call and arrival/departure information etc can be set (memory) in advance, and easy recording can be performed when the information is selected.

### Recording of detailed voyage information

In addition to the usual recording function for ship's heading/rudder angle, at the same time more information like set course/rudder order/ course over ground etc can now be displayed and recorded at the same time. From own ship's drift conditions and rudder feedback conditions etc, detailed voyage information can be used to select the most suitable steering mode, adjust the steering parameter, and confirm the operation of the navigation equipment.

### Easy Information management and recording

Easy to transfer data to a PC using USB memory or CF card. When using the software included, it is possible for data to be viewed or printed with the PC. Also, it is easy to search for memos or events, and manage voyage data.

### Easy to retrofit

Dimensions are the same as the existing Course Recorder. When necessary, a signal converter is installed inside the unit which eliminates the need to change existing wiring making it possible for retrofit of the Course Recorder unit only.



## Screen

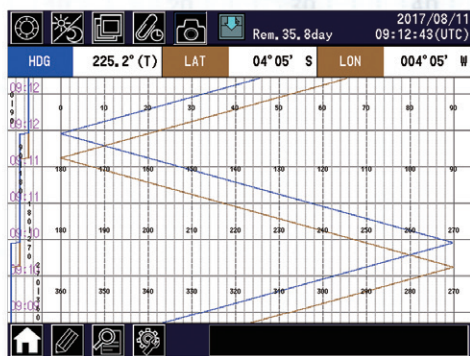

Basic screen (CR-100)

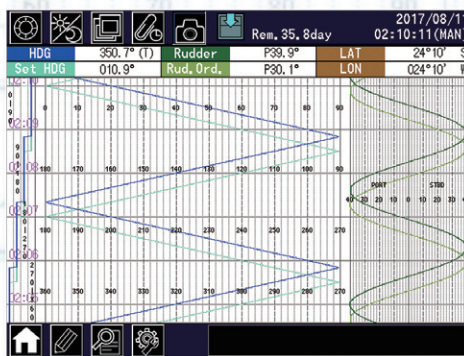

Basic screen (DCR-100)

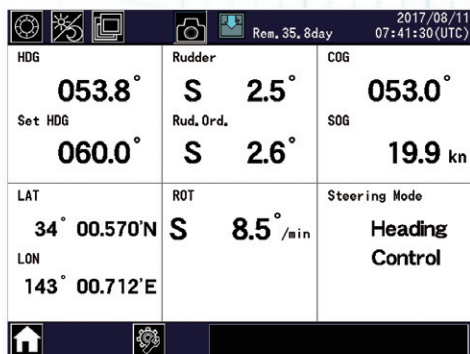

Numerical information screen (DCR-100)

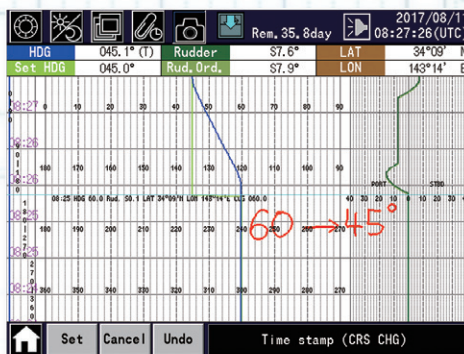

Time stamp and hand written notes (DCR-100)

## Model

### CR-100 Series : Single Channel Course Recorder

### DCR-100 Series : Dual Channel Course Recorder

CR-100 <b>Standard type</b>	Heading information, Time (Serial signal)
CR-150 <b>Retrofit type</b>	Heading information (Step & Synchro signal)
CR-180 <b>Retrofit type</b>	Heading information (Serial signal)

DCR-100 <b>Standard type</b>	Heading information, Rudder angle information, Time (Serial signal)
DCR-150 <b>Retrofit type</b>	Heading information, Rudder angle information (Step & Synchro signal)

## Specification

Main power	DC24V MAX 15VA	Communication specification	3x RS422 serial signal input ports, International Standard IEC61162 compliant
Ambient temperature	-15°C ~ +55°C	Recording information	Heading, actual rudder angle, rudder order, course over ground, speed over ground, latitude, longitude, rate of turn, steering mode, time stamp etc.
Recording media	CF card 4GB Standard, 8GB Optional (USB memory is not included.)	※May differ according to specification.	
Display	10.4 inch TFT Color LCD VGA (640×480) Touch screen		

## Dimensions

### ●Standard type

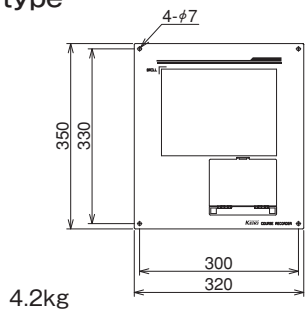

Flush mount type

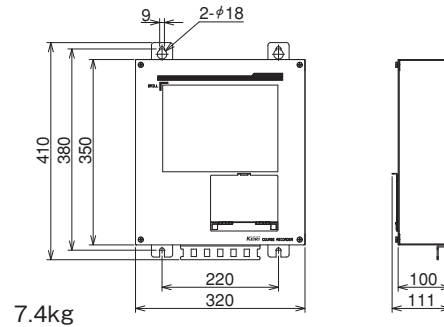

Wall mount type

### ●Retrofit type

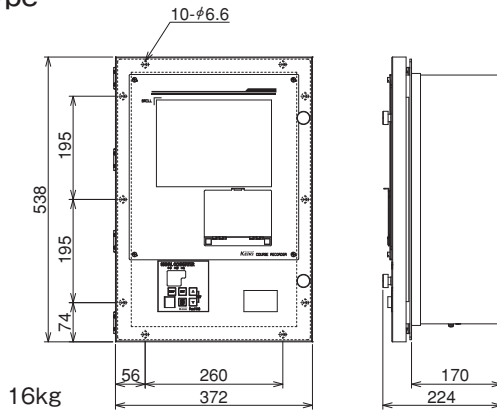

Flush mount type

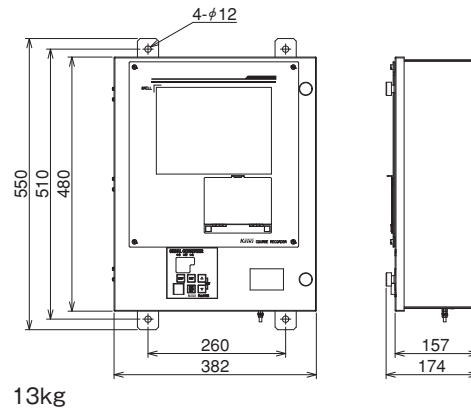

Wall mount type

Design and specifications are subject to change without prior notice, and without any obligation on the part of the manufacturer.



**CAUTION**

Before operating this equipment, you should first thoroughly read the operator's manual.

# TOKYO KEIKI

TOKYO KEIKI INC.

Marine Systems Company

Head Office

2-16-46, Minami-Kamata, Ohta-ku, Tokyo 144-8551 JAPAN  
Tel. +81-3-3737-8611 Fax. +81-3-3737-8663

TOKYO KEIKI (SHANGHAI) CO., LTD.

C-1407, Orient International Plaza. No.85 Lou Shan Guan Rd., Shanghai 200336. CHINA  
Tel. +86-21-3223-1252 Fax. +86-21-6278-7667

TOKYO KEIKI U.S.A., INC.

625 Fair Oaks Ave, Suite190, South Pasadena, California 91030 U.S.A.  
Tel. +1-626-403-1500 Fax. +1-626-403-7400

Busan Liaison Office

Shindonga bldg. Room 1003, 749-1 Gayadaero, Busanjin-gu, Busan 614-783, KOREA  
Tel. +82-51-802-2190 Fax. +82-51-802-2188

Singapore Branch

No.2 Jalan Rajah #07-26/28, Golden Wall Flatted Factory, Singapore 329134  
Tel. +65-6254-1877 Fax. +65-6254-1745

[www.tokyo-keiki.co.jp/marine/e/](http://www.tokyo-keiki.co.jp/marine/e/)